

**SHERLINE  
PRODUCTS**  
INCORPORATED 1974

## W.R. SMITH T-REST

P/N 2110

### The Purpose of a T-Rest

This T-rest was designed by world renowned watch- and clockmaker William R. Smith. The only change we made was to eliminate locking levers from the post and pedestal base and replace them with 10-32 screws for production reasons. The same 5/32" hex key that comes with your Sherline lathe can be used to adjust them.

The T-rest is used to support a metal cutting tool called a "graver" which is hand held rather than held in a tool post like a conventional lathe tool. This is a traditional method of cutting metal shapes that has long been used by watch and clockmakers. It is also used by some instrument makers, modelmakers and machinists.

Because the tool is hand held, there is more "feel" for the cut that is being made. Certain shapes like ball ends and special notches or ridges which would be difficult to make with conventional tools can be done quickly and easily with this technique. It can yield very precise results in the hands of one skilled in this technique; however, a certain amount of practice may be required for a beginner to turn precise parts using this method.

### Precautions for Hand Turning

Do not use this tool on parts held in a 3-jaw or 4-jaw chuck. A graver which inadvertently hits a spinning chuck jaw could be dangerous. Because the tool is hand held, it cannot be held as securely as a tool held in a toolpost, so use it with appropriate caution. The cutting angle, sharpness of the tool, position of the tool point and feed rate of the tool are all critical to how it cuts. In a nutshell, when the angles are right,

the tool cuts. When they're not, it doesn't. Experiment as you find the best combination and get a feel for the process.

### Turning Speeds and Tool Angles

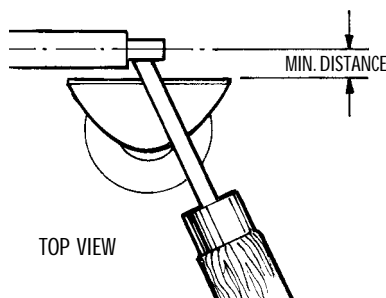
Mr. Smith suggests a turning speed of about 250-500 RPM for turning a small diameter steel shaft. The speeds listed in speed tables for conventional lathe cutting tools do not really apply to cutting with gravers. The basic machining rule does still apply, however and that is:

**"If the tool chatters, reduce speed and increase feed."**

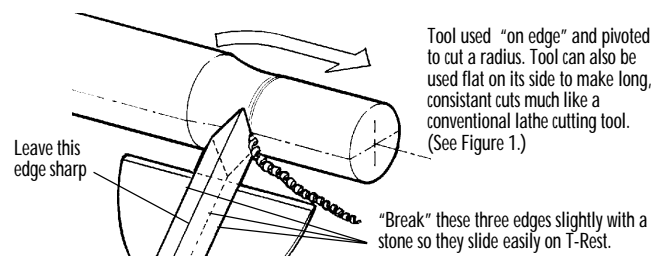
Rest the tool shank on the T-rest with the point of the tool on the top side. (See Figure 2.) Slide it along on the bottom pointed edge, holding the tool in one of the grips shown in the graver instruction sheet. The tool can be rotated and pivoted to be used in any number of ways to achieve the type of cut you desire. The tool should be raked downwards at the handle end about 5° to 7° for cutting hard steels. For softer materials like brass, the rake angle can be reduced to near 0° to keep the tool from biting too deeply into the softer metal.

The angle of entry of the tool into the part varies. Start at about the part centerline and move the tool up or down slightly varying the angle until you find a position where it cuts best. You can pivot the tool left and right using pressure from your finger to swing an arc to cut a radius. As the leading edge of the tool bites in, the heel rubs on the part keeping the tool from digging too deeply. Using this method you can achieve very subtle control of your cut.

I suggest you "break" three of the sharp edges of your graver slightly with a stone so they slide smoothly on the top of the

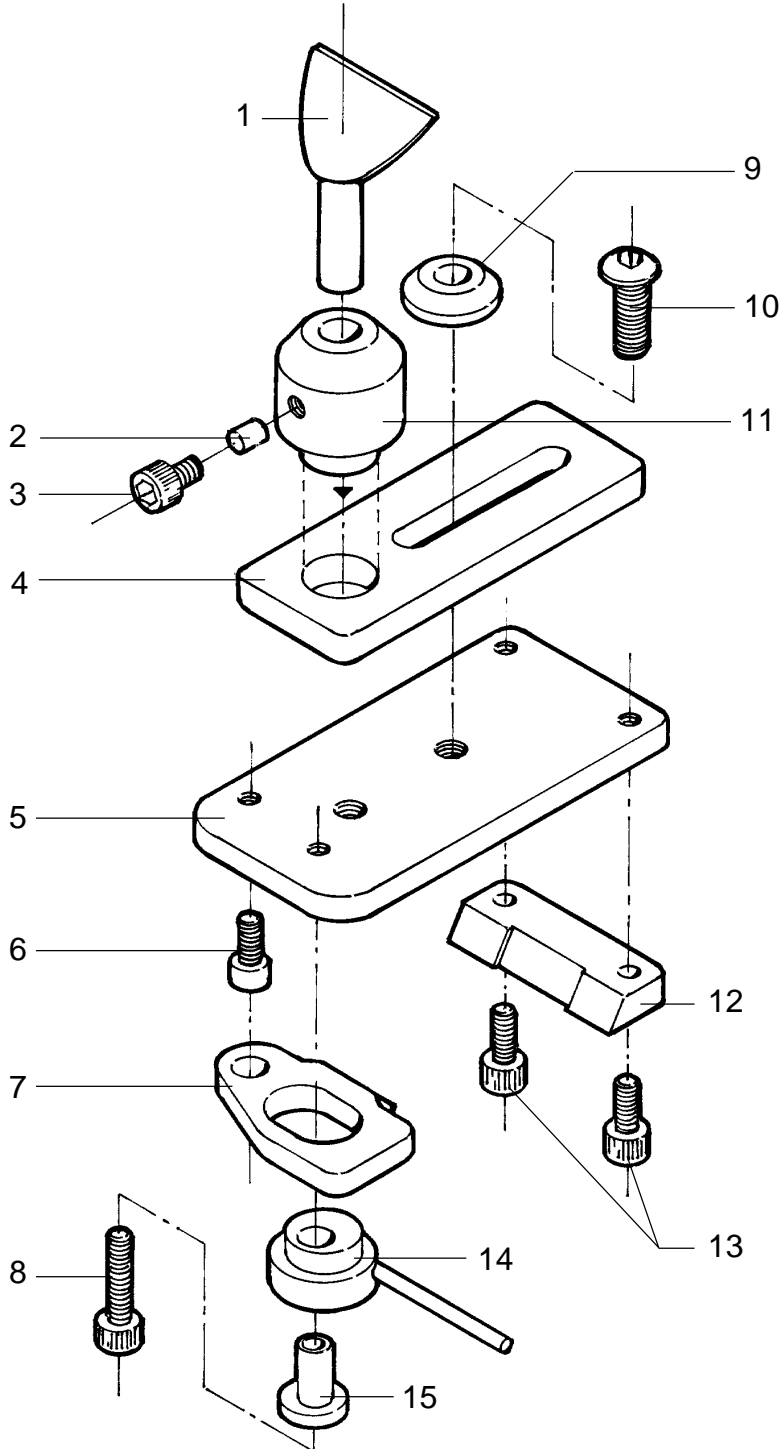


**FIGURE 1**—The T-rest is set close up to the work so that the overhang of the tool is minimal. This gives you better leverage on the tool should it dig into the part. (Tool is shown being used on its side.)



**FIGURE 2**—Metal peels from the edge of the tool when you find the right cutting angle.

## P/N 2110 T-REST EXPLODED VIEW AND PART NUMBERS



NOTE: The small brass cylinder (Part Ref. No. 2) is inside the hole in the side of the T-rest pedestal (Ref. No. 11). It is tightened against the shaft of the T-rest and its soft material prevents damage to the shaft. If the T-rest is raised too high in its hole, the brass cylinder can be pushed into the shaft hole, preventing the shaft from being pushed back down. If this occurs, remove the T-rest and use a small screwdriver blade to push the cylinder back into its hole from inside the shaft hole. Then reinsert the T-rest, adjust to proper height and retighten the locking screw (Ref. No. 3).

T-rest. If the edges are left sharp they will bite in rather than slide.

Mr. Smith gave me a “crash course” on using gravers at his home in Tennessee, but I still don’t feel I have the expertise to write complete instructions for their use. Mr. Smith has kindly given permission to use his instructions on making gravers which are included along with this sheet. He is a superb craftsman and gentleman and we appreciate the opportunity of working with him on this project.

### Where to Get More Information

If you are new to the technique of hand turning metal, I suggest you get more information from Mr. Smith or other experts in the horological field. He has published several books and videos that show or describe the techniques required. He may be reached by calling (865) 947-9671. You may write him at: William R. Smith, 8049 Camberley Drive, Powell, Tennessee 37849-2418. His E-mail address is: wrsmith2@aol.com.

If you are going to be making the precise parts required in clocks, models and instruments, you will find that the Sherline lathe along with the T-rest will yield results equal to those you would obtain on special jeweler’s lathes costing many times more.

—Joe Martin, President and Owner  
SherlineProducts Inc.

### PART NUMBERS

REF NO.	PART NO.	NO. REQ.	DESCRIPTION
1	21200	1	T-Rest
2	21230	1	Brass spacer 5/32" O.D. x 3/16"
3	10850	1	T-Rest Lock Screw, 10-32 x 1/4" Skt Hd Screw
4	21110	1	T-Rest Pedestal Base
5	21150	1	T-Rest Saddle Body
6	10850	1	Cam Pivot Screw (Custom) 10-32 x 1/4" Skt Hd Screw
7	21160	1	Cam Follower
8	40690	1	Cam Mounting Screw 10-32 x 3/4" Skt Hd Screw
9	21140	1	Hold Down Washer
10	21280	1	Pedestal Hold Down Screw 1/4-20 x 5/8" Button Hd Screw
11	21170	1	T-Rest Pedestal
12	21210	1	Dovetail Block
13	40510	2	10-32 x 3/8" Skt Hd Screw
14	21300	1	Cam and Lever Arm
15	21120	1	Cam Spacer Sleeve