

veritas®

Power Tenon Cutters

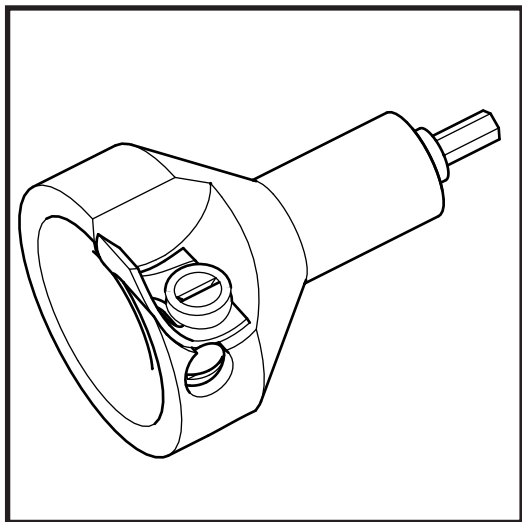

- 05J41.01 – 5/8"
- 05J41.02 – 3/4"
- 05J41.09 – 7/8"
- 05J41.03 – 1"
- 05J41.07 – 1 1/4"
- 05J41.05 – 1 1/2"
- 05J41.08 – 1 3/4"
- 05J41.06 – 2"

Patented.

Safety Rules



These safety instructions are meant to complement those that came with your power tool. We suggest that you reread those, in addition to those listed here before you begin to use this product. To use this product safely, always follow both sets of safety and general instructions.

General Safety Rules

1. Read the manual. Learn the tool's applications and limitations as well as the specific hazards related to the tool.
2. Use common sense. If an action appears to be unsafe, it likely is.
3. Wear proper eye/ear protection. Everyday eyeglasses have only impact-resistant lenses; they are not safety glasses. Also use a face or dust mask if the cutting operation is dusty. Visitors should wear the same protection.
4. Wear proper apparel. Avoid wearing clothing with loose sleeves. Do **not** wear gloves, ties, rings or bracelets as these can get caught in moving machinery.
5. Long hair should be tied back and secured.
6. Do **not** work under the influence of drugs, alcohol, or medication. Drugs, alcohol, medication and lack of sleep cause impaired judgment and coordination and should not be combined with power tool operation.
7. Use in an appropriate environment. Power tools should be used only in dry, clean and well-lit environments. Exposure to rain or use in the presence of flammable liquids or gases could result in damage or injury.
8. Do **not** operate electric tools in gaseous or explosive environments. The spark of the motor may cause the fumes to ignite.
9. Keep workplace clean. Cluttered areas and benches invite accidents.
10. Use correct power supply. Never use a power source for which this tool was not designed. It could cause serious injury. If the tool is equipped with a three-prong plug, it should be plugged into a three-hole electric receptacle. An adapter should be properly grounded.
11. Keep cord away from heat, oil and sharp edges.
12. Do **not** carry a plugged-in portable tool with finger on the switch.

13. Never carry portable tools by the cord.
14. Use the right tool. Do **not** force a small tool or attachment to do the job of a heavy-duty tool.
15. Do **not** force tool. It will do the job better and safer at the rate for which it was designed.
16. Do **not** use damaged tools. A damaged tool that does not operate correctly is a safety hazard and should be fixed before any further use.
17. Repairs and service should be performed by a certified technician. Use only identical replacement parts.
18. Do **not** alter or misuse the tool. Stop any operation immediately if you notice anything abnormal.
19. Practice proper maintenance. Keep all tools sharp, clean and well lubricated for the best and safest results. Sharp blades minimize stalling, kickback, and burning. They perform faster, better and safer than dull blades.
20. Keep hands away from moving parts until they have come to a complete stop and the power has been disconnected.
21. **Always** disconnect the tool from the power source when changing cutters or blades, or when performing any general maintenance activities (such as adjusting or cleaning).
22. Handle blades with care.
23. Unless otherwise specified, always insert the shank as far as possible into the chuck in order to provide proper support. Tighten the chuck securely.
24. Remove all nails from a workpiece before performing any operation on it.
25. Hold workpiece firmly in a vise or clamp.
26. Ensure that depth and any other adjustments are tight.
27. Remove adjusting keys and wrenches before use.
28. Maintain good balance.
29. Do **not** remove workpiece or cut-off pieces from tool during a cut while the cutter is moving.
30. Do **not** leave tool until it comes to a complete stop.
31. When not in use, power tools should be stored in a dry area, elevated and locked so that they are out of the reach of children.



The Veritas® Power Tenon Cutters make round tenon cutting for rustic furniture quick, accurate and easy. Each has been balanced to minimize vibration while being driven with an electric drill, and an integral level vial helps you keep the tenon cutter level. The blade is adjustable to cut the exact size of tenon required. It is easy to sharpen the blade with the integral sharpening jig that holds the blade at the optimum angle.

Veritas® Tenon Cutters are for use in a hand electric drill. They are **not** to be used in a drill press for several reasons.

- 1) Because the workpiece must be rigidly clamped in line with the equally rigid axis of the drill-press chuck, any misalignment or movement can create high side loads on the tenon cutter, leading to the shank failing. Any quill run-out in the drill press contributes further to the problem.
- 2) Because there is much less feel as to how the cutter is performing when using a drill press, it is possible to overload the tenon cutter without realizing it. This too can lead to the shank failing.
- 3) Overloading the tenon cutter or operating it at high speeds can also lead to overheating the high-carbon steel blade, resulting in edge failure, loss of hardness, and a useless blade.

Taking a Test Cut

Firmly tighten the tenon cutter in the chuck of an electric drill. For the large-size tenon cutters (1 1/4" to 2" dia.) a minimum 1/2"

chuck is required, and a high-torque, low-speed (~500 rpm) drill is recommended.

Clamp a piece of wood horizontally in a vise at about waist height. Use a piece no larger than the diameter specified in Table 1 for the tenon cutter to be used. Ensure the end is cut square. Putting a substantial chamfer on the end of a piece of wood that is at or close to the upper limit of the tenon cutter's capacity will make starting the cut much easier.

Tenon Dia.	Max. Stock Dia.
5/8" to 1" 1 1/4" to 2"	Tenon Dia. + 1 1/8" Tenon Dia. + 1 1/2"

Table 1: Maximum Wood Diameter for Tenon Cutter Diameter.

***Hint:** If you do not have a vise, you can improvise with a piece of 2x4 with various sizes of V-shaped notches cut in it and two C-clamps. Place the piece of wood in a notch slightly smaller than its diameter, and clamp the 2x4 to a bench or any large stable surface.*

Place the tenon cutter on the end of the piece of wood and rotate the tenon cutter by hand until the level vial is at the top. Raise or lower the drill until the bubble is centered in the vial. Adjust the drill left or right by eye so that it is in line with the piece of wood.

It is important to realize that the tenon cutter will cut tenons in line with the axis of the drill. If you wish to have a tenon come off the end of the piece of wood at an angle, clamp the piece in a vise at the desired angle (using an inclinometer if necessary). Cut the tenon while holding the tenon cutter straight and level, using the level vial as an indicator.

Note: Whether you are cutting in-line or angled tenons, the secret to cutting a uniform tenon is to keep the drill very steady while cutting.

While leaning into the wood, switch on the drill at a moderate speed (500 to 700 rpm for $\frac{5}{8}$ " to 1" dia. tenons, 100 to 200 rpm for $1\frac{1}{4}$ " to 2" dia. tenons). Turning too fast may cause you to wander from a straight cut. If the blade is properly set, a long continuous shaving of wood will curl out of the tenon cutter as it rotates. If the tenon cutter stops cutting or does not cut at all, you will need to adjust the blade.

Adjusting the Blade

There are two adjustments that can be made to the tenon cutter. The one you will use most often is the blade advance to obtain the desired tenon diameter. The second adjustment allows you to reduce the thickness of cut.

To Adjust Tenon Diameter:

To adjust the blade, back off the clamping screw about one half turn if you intend to advance the blade, or fully relieve the pressure if you need to retract the blade (see Figure 1). Advance or retard the blade advance screw by about one half turn, retighten and test. Repeat until you can cut a continuous shaving of wood. Then test the tenon for size. To fine tune it, remember that advancing the blade will reduce tenon diameter and vice versa.

Note: Never adjust the blade without first loosening the blade clamping screw as you may damage your tenon cutter.

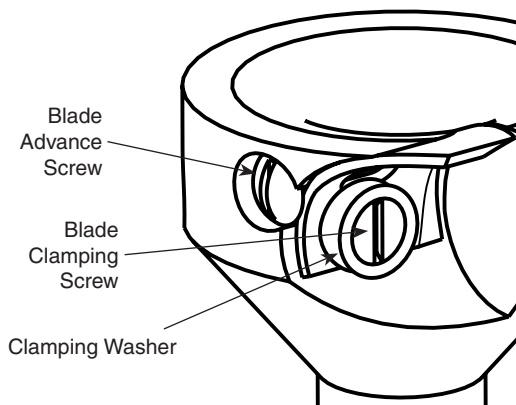

Figure 1: Adjusting the Blade.

In some instances, you may find that backing the blade off to its minimum projection into the main bore will still not yield a tenon sufficiently large for a snug fit into your mating hole. By cutting a $\frac{1}{8}$ " wide strip of the included 0.010" thick shim and placing it between the blade and the body (just behind the blade clamping screw), the maximum tenon size will be increased by approximately 0.020" (see Figure 2).

Note: Only one shim may be added in this location; adding more will elevate the blade beyond the point at which the blade can still cut the tenon.

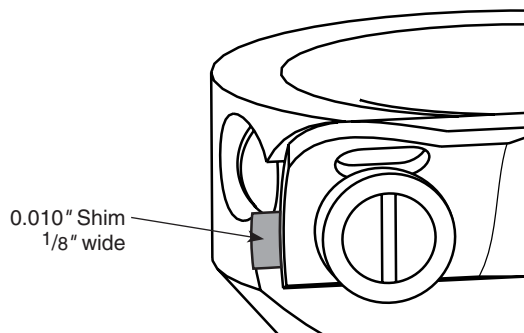

Figure 2: Shimming the Blade to Increase the Tenon Size.

To Adjust Shaving Thickness:

The tenon cutter is designed to cut a 0.030" thick shaving at the largest portion of the tenon shoulder, decreasing in thickness as it reaches the main bore. Depending on the size of shoulder and dryness of the wood being cut, you may want to reduce this. For example, cutting a 1" tenon on a 2¹/₈" stick will produce a large shoulder, so a correspondingly large surface area of wood must be cut away. By cutting the 0.010" thick shim into 1/8" to 1/4" wide strips and placing one or more between the blade and the body near the mouth, the shaving thickness will be reduced (see Figure 3). While it will take longer to produce a tenon with a smaller shaving, less torque is required to turn the cutter and control is improved.

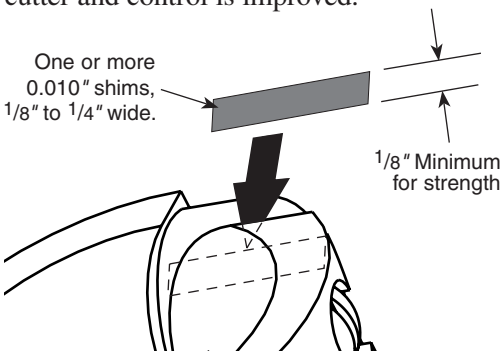

Figure 3: Shimming the Blade to Reduce Shaving Thickness.

Setting the Tenon Length

A tenon cut to full depth will be 2³/₄" long with the 5/8" to 1" dia. tenon cutters, and 4¹/₄" long with the 1¹/₄" to 2" dia. tenon cutters. (**Note:** tenon lengths do not include the 3/4" long shoulder). Tenon length can be reduced by making a depth stop using the rare-earth magnet that comes attached to the back end of the hex drive. With the blade advanced to

cut the minimum tenon size, cut a full-length tenon. Cut off the end of this tenon to obtain a dowel of the required length; dowel length = (tenon length without depth stop) - desired tenon length (see Figure 4). Counterbore a hole in the center of one end, only deep enough to house the magnet. Bond the magnet into the hole using epoxy adhesive. Pop the magnetic depth stop into the tenon cutter until it adheres to the bottom of the bore. Stab it with a scratch awl to remove it.

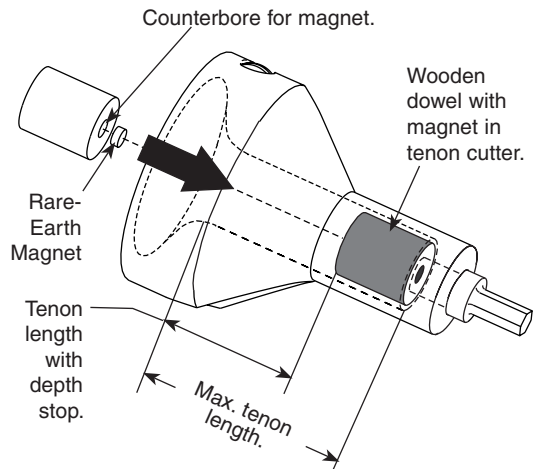

Figure 4: Depth Stop.

Sharpening

The body of the tenon cutter has a side flute for use as a sharpening jig. Move the blade from the cutting position to the sharpening position (as shown) and fix it in position with the blade clamping screw placed in the central slot in the blade.

Note: The 1¹/₄" to 2" dia. tenon cutters contain a 3/8" long screw in the side flute. This may be used to fix the blade in position for sharpening. Its primary purpose, however, is to allow a blade that has been shortened from repeated sharpenings to

be sufficiently advanced. This will become evident when the 1/2" long blade advance screw bottoms out in its counterbored hole before the blade is sufficiently advanced. This is the time to switch the two screws.

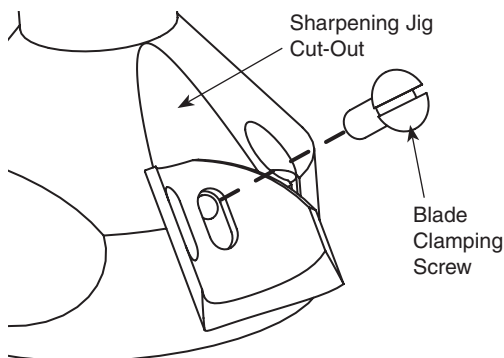

Figure 5: Blade Mounting for Sharpening.

You can now sharpen the blade on a 1 1/2" sanding drum mounted in a drill press. We recommend a silicon carbide sleeve (80x if you have a nick to remove followed by 120x for regular honing). Set the drill-press spindle speed between 1000 and 2400 rpm. Coat the entire bevel of the blade with an indelible marker. Using the tenon cutter body as the sharpening jig (see Figure 6), firmly but gently slide the tenon cutter body and blade into the drum. Do not hold the blade in contact with the drum for extended periods of time (more than a few seconds) or you may overheat the blade.

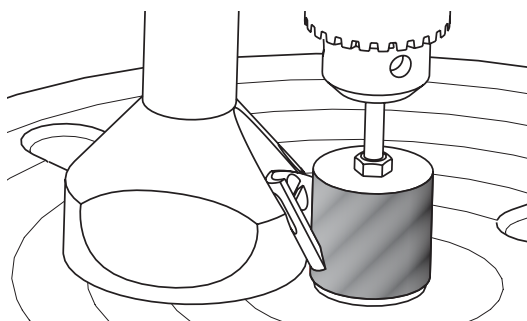

Figure 6: Blade Sharpening.

Observe where the marker coating has worn off. Continue sharpening until the entire blade edge is clear of marker coating (at least 1/32" wide) and all nicks have been removed (see Figure 7). Vary the height of the drill-press table from time to time as you sharpen to distribute the wear on the sleeve.

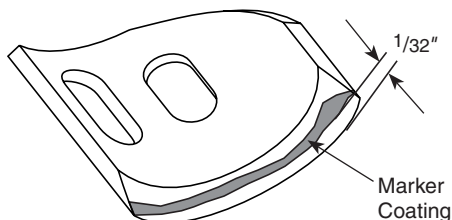

Figure 7: Blade Detail.

Remove the blade from the sharpening jig cut-out. To remove the wire burr from the edge of the blade, simultaneously swipe and roll the outside radius of the blade across a fine grit (1000x or higher) sharpening stone or piece of silicon carbide abrasive paper on a flat surface (see Figure 8).

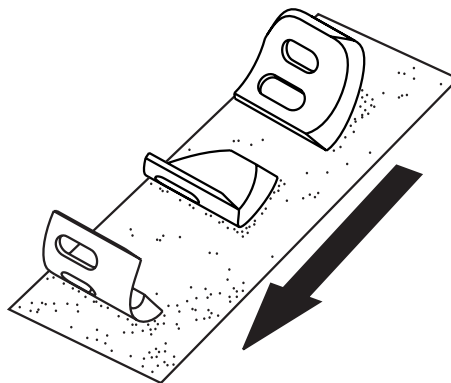

Figure 8: Removing Burr.

Because the blade has been sharpened and is now slightly shorter, it will require an adjustment. Re-install the blade and adjust it as previously described until you are able to cut continuous shavings and the tenon is the correct size.

Troubleshooting

UNEVEN TENONS: This is usually caused by an unsteady drill position while cutting. Reduce your drill speed and concentrate on holding the drill steady while cutting.

UNDERSIZED TENONS: These usually indicate a blade that has been advanced too far. Back off the blade and try another cut.

SCALLOPED TENONS: Applying excessive force while cutting the tenon can result in the cutter advancing at a rate fast enough to make the tenon look like a coarse thread. Reduce the inward force applied to the drill or add shims to reduce the shaving thickness.

Continuing to rotate the tenon cutter clockwise while withdrawing it from the tenon can also cause the blade to cut on its return pass, leaving similar scallops. This is especially so on green wood, where some compression may have taken place as the tenon was being cut. Instead, pull the tenon cutter off the tenon with the drill switched off, either without rotating it, or by slowly rotating it counterclockwise.

OFF-CENTER TENONS: Nothing can be done about the most common cause of off-center tenons — natural variations in wood density and growth patterns.

The other cause, when the tenon wanders off-center during the initial shoulder cut, can be controlled to a degree. Smaller pieces have less tendency to exhibit this because the initial square-cut ends contact the bell-mouth at a fairly steep angle. Wood pieces that are

near the upper limit of the tenon cutter's capacity contact the bell-mouth where that contact angle is much shallower, thus not as easily guided into the main bore. Press the drill hard into the wood piece, only until the tenon shoulder is formed. At that point, reduce the inward pressure; otherwise, a scalloped tenon may result. Putting a substantial chamfer on the end of a piece of wood that is at or close to the upper limit of the tenon cutter's capacity will make starting the cut much easier.

PARTIAL TENONS: If the tenon cutter starts cutting, then fades and eventually stops cutting, this indicates that a minor blade adjustment is required. Advance the blade a half turn or less and retest.

If the blade adjustment does not solve the problem, another cause might be an off-center tenon. With large pieces of wood, the tenon may wander off-center, producing uneven shoulders and causing the tenon cutter to stop cutting. Remove some of the excess material to even out the shoulders, then continue to cut the tenon.

UNEVEN GRIND WHEN RESHARPENING: This usually happens when the drill-press table on which the tenon cutter is resting is not square to the quill. Adjust the table using a straight pin chucked in the drill press and a square on the table.

The other cause may be due to slight variation in diameter between individual sanding sleeves. The bevel on your blade may change slightly as a result, but this will not affect the performance of the tenon cutter.

Replacement Blade and Accessories

Product #	Description
05J41.11	Replacement Blade (all sizes)
50J62.01	Sanding Drum, 1 1/2" x 1 1/2"
50J62.02	80x SiC Sleeves, package of 3
50J62.03	120x SiC Sleeves, package of 3
54K93.02	8 1/2" x 11" Micro-Abrasive Sheet (15 μ SiC, PSA)
99K31.01	0.25" x 0.10" Rare-Earth Magnet
99K31.03	0.50" x 0.125" Rare-Earth Magnet

Other Sizes of Tenon Cutters Available

Product #	Description
05J42.01	Mini Tenon Cutter – 1/4"
05J42.05	Mini Tenon Cutter – 5/16"
05J42.02	Mini Tenon Cutter – 3/8"
05J42.06	Mini Tenon Cutter – 7/16"
05J42.03	Mini Tenon Cutter – 1/2"
05J42.04	Mini Tenon Cutter – 9/16"

veritas[®] Tools Inc.

814 Proctor Avenue
Ogdensburg, New York
13669-2205 USA

1090 Morrison Drive
Ottawa, Ontario
K2H 1C2 Canada